

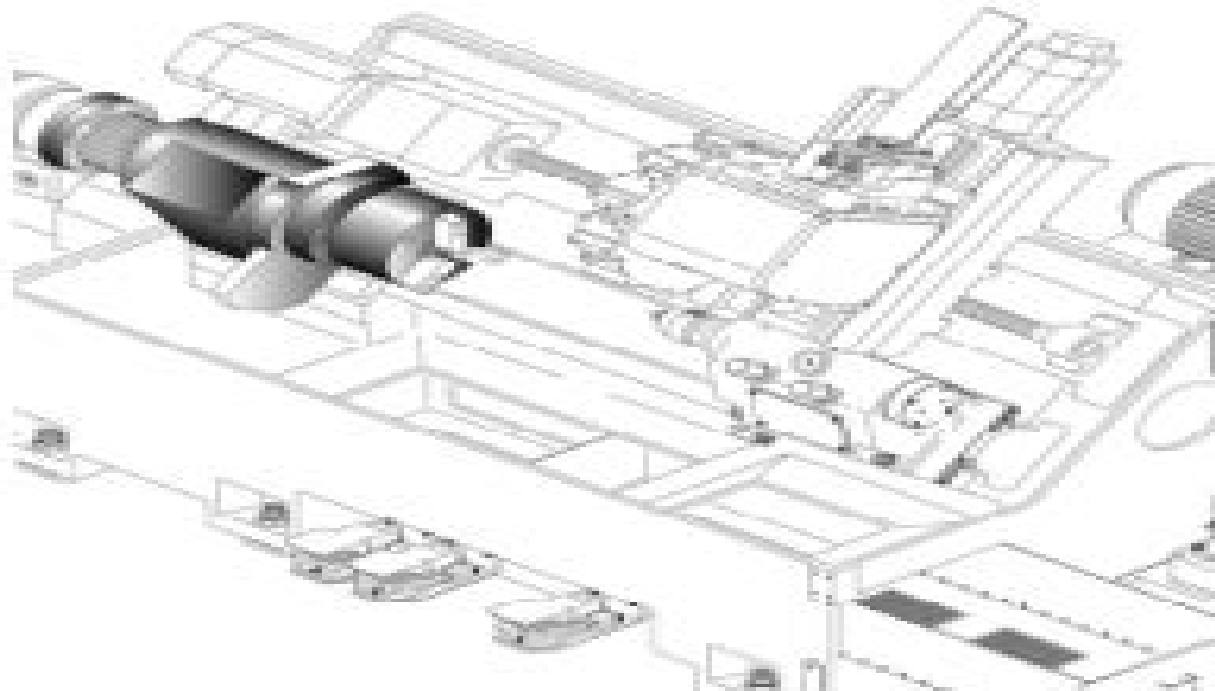

Doosan Infracore  
Machine Tools

## NC-Programming Manual for Turning Centers with Fanuc 30 Series Controls



# Doosan Cnc Operators Manual

**Alan Overby**



## **Doosan Cnc Operators Manual:**

### **A Comprehensive Guide to CNC Machines: Types, Functions, Applications, Safety Measures, and Operators**

MR. BIG WEALTH,2023-09-07 Our comprehensive guide to CNC machines is a must have resource for anyone interested in understanding the intricacies of these advanced machines Whether you are a beginner or an experienced operator this guide covers everything you need to know about CNC machines from the different types and their functions to the various applications and safety measures With detailed information and practical tips this guide empowers operators to maximize the potential of CNC machines while ensuring a safe working environment Get ready to dive into the world of CNC machines with our comprehensive guide and take your knowledge and skills to the next level

**Sustainable Design and Manufacturing 2019** Peter Ball,Luisa Huaccho Huatuco,Robert J. Howlett,Rossi Setchi,2019-06-27 This volume consists of 52 peer reviewed papers presented at the International Conference on Sustainable Design and Manufacturing SDM 19 held in Budapest Hungary in July 2019 Leading edge research into sustainable design and manufacturing aims to enable the manufacturing industry to grow by adopting more advanced technologies and at the same time improve its sustainability by reducing its environmental impact The topic includes the sustainable design of products and services the sustainable manufacturing of all products energy efficiency in manufacturing innovation for eco design circular economy industry 4 0 industrial metabolism automotive and transportation systems Application areas are wide and varied The book will provide an excellent overview of the latest developments in the Sustainable Design and Manufacturing Area

*Moody's Transportation Manual* ,1996 *Machinery Buyers' Guide* ,2003 **Operating Manual for Jones and Lamson CNC "A" Line Machine** ,1983 **Operating Manual for the Series I CNC Milling, Drilling and Boring Machine, BOSS 4, 5 and 6 Systems** Textron, Inc. Bridgeport Machines Division,1980

**CNC Programming Handbook** Peter Smid,2008 This latest edition of a popular reference contains a fully functional shareware version of CNC toolpath simulator editor NCPlott on the CD ROM a detailed section on CNC lathes with live tooling image files of many actual parts the latest Fanuc and related control systems and much more

**Instruction Manual for Engineering Craftsmen** Engineering Industry Training Board,1982 **CNC Machining Certification Exam Guide** Ken Evans,2019-09-17 CNC Machining Certification Exam Guide is focused on providing the knowledge base required for obtaining certification credentialing and or job preparation in CNC Machining with CNC Mills and Lathes It covers foundational skills that all those seeking employment as a CNC Operator Machinist must possess Managers responsible for workforce development in manufacturing facilities will use the book as a guide for on the job employee training and apprenticeships The work can be used as a curriculum component for technical schools and colleges for students preparing for certification and credentialing exams based on the National Institute for Metalworking Skills NIMS Machining Level I standards for CNC Mill Programming and Setup and Operations and CNC Lathe Programming and Setup and Operations At a

time when the CNC market is experiencing a shortfall of skilled qualified workers this Exam Guide is the perfect resource Features Presents CNC Programming with G Code so users can execute their programs with confidence Focuses on the creation of CNC programs using Computer Aided Manufacturing CAM Written with the end goals of certification credentialing and job readiness in mind Practice study questions mimic those presented on credentialing exams and practice exercises prepare readers for the required practical activities An affiliated website [www.CNCCertification.com](http://www.CNCCertification.com) will contain additional certification questions and answers as well as suggested additional exercises

**NC/CNC Machining II for Engineering Craftsmen** Engineering Industry Training Board,1982 **CNC Programming Techniques** Peter Smid,2006 This practical and very useful resource covers several programming subjects including how to program cams and tapered end mills that are virtually impossible to find anywhere Other more common subjects such as cutter radius offset and thread milling are covered in great depth

**Managing Computer Numerical Control Operations** Mike Lynch,1995 Provides the ideas guidelines and techniques you need to capture the full potential of your CNC equipment Nearly every aspect of CNC operations is addressed and the book is organized so you can use it as a step by step guide to efficient CNC utilization or as a shop floor reference for continuous improvement Hundreds of specific utilization boosting techniques are detailed

**The Complete CNC Master Handbook** Nishioka Yoshihiro,2024-12-03 This definitive guide is your all in one resource to master the intricacies of Computer Numerical Control CNC machining Whether you re a seasoned machinist or a curious beginner this handbook provides a clear and concise pathway to CNC excellence Key Features In Depth Exploration Delve into the fundamental principles of CNC machining from basic concepts to advanced techniques Practical Guidance Learn hands on skills for operating setting up and programming CNC machines with precision and efficiency Real World Applications Discover real world examples and case studies to apply your knowledge to practical scenarios Troubleshooting Tips Gain valuable insights into common CNC challenges and effective troubleshooting strategies Step by Step Tutorials Follow along with detailed tutorials to master essential CNC skills from toolpath generation to machine calibration Comprehensive Reference Utilize the book as a valuable reference tool for quick access to important information and best practices Who This Book Is For CNC Operators Enhance your skills and become a more proficient CNC operator Machinists Expand your expertise and transition into CNC machining with confidence Engineers Gain a deeper understanding of CNC technology and its applications in manufacturing Students and Hobbyists Explore the world of CNC machining and develop practical skills Elevate your CNC mastery with The Complete CNC Master Handbook Your journey to CNC success starts here **CNC Machining Handbook** James Madison,1996 A reference handbook detailing CNC machining centers commonly used CNC commands and related production tooling Written for programmers engineers and operators the reference supplies basic theory and procedures covering milling boring turning grinding and CNC tooling The CNC commands are referenced by graphical representation of the toolpath and generic commands are cross referenced by

industry standard formats Includes illustrations Lacks an index Annotation copyright by Book News Inc Portland OR 7  
*Easy Steps to CNC Programming . . . Book II* David S. Hayden,2003 7 Easy Steps to CNC Programming Book II Beyond the Beginning is the second book in a series of introductory books on CNC Programming This book picks up where Easy Steps to CNC Programming A Beginner s Guide leaves off This books has a Frequently Asked Questions sections advanced information on Coordinates systems NURBS how to select a CAM system How to hire programmers etc *Machine Shop Trade Secrets* James Harvey,2013 A Treasure Trove of Practical Tips and Tricks for CNC Machining From the author of the bestselling and universally praised Machine Shop Trade Secrets comes a new manual that does for CNC machining what the first book did for conventional machining With this guide to proven CNC machine shop practices you will be producing machine parts faster with fewer errors and with less labor You ll discover that you don t have to know everything there is to know to make parts on CNC machines just as for example you don t have to know everything about Microsoft Word towrite a letter Whether you are a shop owner machinist designer or hobbyist you will find yourself referring to this manual again and again In this manual you will discover Easy to read steps for going from print to part using CAD CAM equipment Useful techniques for holding and machining parts using CNC machines Ways to unravel the mysteries of using G code Ways to avoid Crashing 3D CNC milling basics What CNC machines can and cannot do Solidwork challenges to improve your modeling skills Ideas for how engineers and designers can help machinists get the job done A potpourri of practical and proven machining tips and tricks **The Journeyman's Guide to Cnc Machines** Bryan Hurst,2006-06-01 The Guide provides instruction in ISO code programming for Turning included are examples that will give an understanding of the principles to apply to any machine and control also featured are GE Fanuc and Siemens Controls The Guide lists functions and codes under the reference JG and provides space to include data for specific machines and controls Extensive examples show how to programme the options and features Component drawings have metric and imperial dimensions simply substitute the dimensions with those of the system of your choice The Guide is your starting point use the instructions and suggestions to build your own unique evolvable folder from here creating an invaluable personal handbook **CNC Trade Secrets** James Harvey,2014-09-15 This book is about computer numerical control CNC machine shop practices Features include over 100 4 color photos throughout easy to read steps for going from print to part using CAD CAM equipment useful techniques for holding and machining parts using CNC machines ways to unravel the mysteries of using G code ways to avoid crashing 3D CNC milling basics what CNC machines can and cannot do solidworks challenges to improve your modeling skills ideas for how engineers and designers can help machinists get the job done practical and proven machining tips and tricks *CNC Machining Handbook: Building, Programming, and Implementation* Alan Overby,2010-10-06 A Practical Guide to CNC Machining Get a thorough explanation of the entire CNC process from start to finish including the various machines and their uses and the necessary software and tools CNC Machining Handbook

describes the steps involved in building a CNC machine to custom specifications and successfully implementing it in a real world application Helpful photos and illustrations are featured throughout Whether you re a student hobbyist or business owner looking to move from a manual manufacturing process to the accuracy and repeatability of what CNC has to offer you ll benefit from the in depth information in this comprehensive resource CNC Machining Handbook covers Common types of home and shop based CNC controlled applications Linear motion guide systems Transmission systems Stepper and servo motors Controller hardware Cartesian coordinate system CAD computer aided drafting and CAM computer aided manufacturing software Overview of G code language Ready made CNC systems

As recognized, adventure as competently as experience nearly lesson, amusement, as well as promise can be gotten by just checking out a books **Doosan Cnc Operators Manual** next it is not directly done, you could recognize even more roughly speaking this life, in this area the world.

We allow you this proper as without difficulty as simple quirk to get those all. We give Doosan Cnc Operators Manual and numerous books collections from fictions to scientific research in any way. in the midst of them is this Doosan Cnc Operators Manual that can be your partner.

<https://yousky7.com/results/browse/HomePages/Beginner%20Tutorial%20For%20What%20Is%20Index%20Fund%20Investing%20Ideas.pdf>

## **Table of Contents Doosan Cnc Operators Manual**

1. Understanding the eBook Doosan Cnc Operators Manual
  - The Rise of Digital Reading Doosan Cnc Operators Manual
  - Advantages of eBooks Over Traditional Books
2. Identifying Doosan Cnc Operators Manual
  - Exploring Different Genres
  - Considering Fiction vs. Non-Fiction
  - Determining Your Reading Goals
3. Choosing the Right eBook Platform
  - Popular eBook Platforms
  - Features to Look for in an Doosan Cnc Operators Manual
  - User-Friendly Interface
4. Exploring eBook Recommendations from Doosan Cnc Operators Manual
  - Personalized Recommendations
  - Doosan Cnc Operators Manual User Reviews and Ratings
  - Doosan Cnc Operators Manual and Bestseller Lists

5. Accessing Doosan Cnc Operators Manual Free and Paid eBooks
  - Doosan Cnc Operators Manual Public Domain eBooks
  - Doosan Cnc Operators Manual eBook Subscription Services
  - Doosan Cnc Operators Manual Budget-Friendly Options
6. Navigating Doosan Cnc Operators Manual eBook Formats
  - ePub, PDF, MOBI, and More
  - Doosan Cnc Operators Manual Compatibility with Devices
  - Doosan Cnc Operators Manual Enhanced eBook Features
7. Enhancing Your Reading Experience
  - Adjustable Fonts and Text Sizes of Doosan Cnc Operators Manual
  - Highlighting and Note-Taking Doosan Cnc Operators Manual
  - Interactive Elements Doosan Cnc Operators Manual
8. Staying Engaged with Doosan Cnc Operators Manual
  - Joining Online Reading Communities
  - Participating in Virtual Book Clubs
  - Following Authors and Publishers Doosan Cnc Operators Manual
9. Balancing eBooks and Physical Books Doosan Cnc Operators Manual
  - Benefits of a Digital Library
  - Creating a Diverse Reading Collection Doosan Cnc Operators Manual
10. Overcoming Reading Challenges
  - Dealing with Digital Eye Strain
  - Minimizing Distractions
  - Managing Screen Time
11. Cultivating a Reading Routine Doosan Cnc Operators Manual
  - Setting Reading Goals Doosan Cnc Operators Manual
  - Carving Out Dedicated Reading Time
12. Sourcing Reliable Information of Doosan Cnc Operators Manual
  - Fact-Checking eBook Content of Doosan Cnc Operators Manual
  - Distinguishing Credible Sources
13. Promoting Lifelong Learning



- Utilizing eBooks for Skill Development
  - Exploring Educational eBooks
14. Embracing eBook Trends
- Integration of Multimedia Elements
  - Interactive and Gamified eBooks

### **Doosan Cnc Operators Manual Introduction**

Free PDF Books and Manuals for Download: Unlocking Knowledge at Your Fingertips In today's fast-paced digital age, obtaining valuable knowledge has become easier than ever. Thanks to the internet, a vast array of books and manuals are now available for free download in PDF format. Whether you are a student, professional, or simply an avid reader, this treasure trove of downloadable resources offers a wealth of information, conveniently accessible anytime, anywhere. The advent of online libraries and platforms dedicated to sharing knowledge has revolutionized the way we consume information. No longer confined to physical libraries or bookstores, readers can now access an extensive collection of digital books and manuals with just a few clicks. These resources, available in PDF, Microsoft Word, and PowerPoint formats, cater to a wide range of interests, including literature, technology, science, history, and much more. One notable platform where you can explore and download free Doosan Cnc Operators Manual PDF books and manuals is the internet's largest free library. Hosted online, this catalog compiles a vast assortment of documents, making it a veritable goldmine of knowledge. With its easy-to-use website interface and customizable PDF generator, this platform offers a user-friendly experience, allowing individuals to effortlessly navigate and access the information they seek. The availability of free PDF books and manuals on this platform demonstrates its commitment to democratizing education and empowering individuals with the tools needed to succeed in their chosen fields. It allows anyone, regardless of their background or financial limitations, to expand their horizons and gain insights from experts in various disciplines. One of the most significant advantages of downloading PDF books and manuals lies in their portability. Unlike physical copies, digital books can be stored and carried on a single device, such as a tablet or smartphone, saving valuable space and weight. This convenience makes it possible for readers to have their entire library at their fingertips, whether they are commuting, traveling, or simply enjoying a lazy afternoon at home. Additionally, digital files are easily searchable, enabling readers to locate specific information within seconds. With a few keystrokes, users can search for keywords, topics, or phrases, making research and finding relevant information a breeze. This efficiency saves time and effort, streamlining the learning process and allowing individuals to focus on extracting the information they need. Furthermore, the availability of free PDF books and manuals fosters a culture of continuous learning. By removing financial barriers, more people can access educational resources and pursue lifelong learning, contributing to

personal growth and professional development. This democratization of knowledge promotes intellectual curiosity and empowers individuals to become lifelong learners, promoting progress and innovation in various fields. It is worth noting that while accessing free Doosan Cnc Operators Manual PDF books and manuals is convenient and cost-effective, it is vital to respect copyright laws and intellectual property rights. Platforms offering free downloads often operate within legal boundaries, ensuring that the materials they provide are either in the public domain or authorized for distribution. By adhering to copyright laws, users can enjoy the benefits of free access to knowledge while supporting the authors and publishers who make these resources available. In conclusion, the availability of Doosan Cnc Operators Manual free PDF books and manuals for download has revolutionized the way we access and consume knowledge. With just a few clicks, individuals can explore a vast collection of resources across different disciplines, all free of charge. This accessibility empowers individuals to become lifelong learners, contributing to personal growth, professional development, and the advancement of society as a whole. So why not unlock a world of knowledge today? Start exploring the vast sea of free PDF books and manuals waiting to be discovered right at your fingertips.

### **FAQs About Doosan Cnc Operators Manual Books**

How do I know which eBook platform is the best for me? Finding the best eBook platform depends on your reading preferences and device compatibility. Research different platforms, read user reviews, and explore their features before making a choice. Are free eBooks of good quality? Yes, many reputable platforms offer high-quality free eBooks, including classics and public domain works. However, make sure to verify the source to ensure the eBook credibility. Can I read eBooks without an eReader? Absolutely! Most eBook platforms offer web-based readers or mobile apps that allow you to read eBooks on your computer, tablet, or smartphone. How do I avoid digital eye strain while reading eBooks? To prevent digital eye strain, take regular breaks, adjust the font size and background color, and ensure proper lighting while reading eBooks. What the advantage of interactive eBooks? Interactive eBooks incorporate multimedia elements, quizzes, and activities, enhancing the reader engagement and providing a more immersive learning experience. Doosan Cnc Operators Manual is one of the best book in our library for free trial. We provide copy of Doosan Cnc Operators Manual in digital format, so the resources that you find are reliable. There are also many Ebooks of related with Doosan Cnc Operators Manual. Where to download Doosan Cnc Operators Manual online for free? Are you looking for Doosan Cnc Operators Manual PDF? This is definitely going to save you time and cash in something you should think about.

**Find Doosan Cnc Operators Manual :**

*beginner tutorial for what is index fund investing ideas*

**best strategies for new roth ira guide**

advanced methods for new saving money tips ideas

advanced methods for how to debt payoff strategies for beginners

easy debt payoff strategies

best strategies for why index fund investing

complete guide to quick debt payoff strategies ideas

**beginner tutorial for quick saving money tips ideas**

*beginner tutorial for trending high yield savings tips*

complete guide to top roth ira ideas

**best strategies for why how to invest**

beginner tutorial for best debt payoff strategies step by step

complete guide to what is roth ira ideas

~~beginner tutorial for how to passive income ideas 2025~~

*best personal finance ideas*

**Doosan Cnc Operators Manual :**

**constitution cogic justice** - Jun 21 2022

web only the general assembly can change that they are the only law making doctrine expressing body in cogic here is the official manual of the church of god in christ in e format here is the green and white book in e format the certified

amendments were the ones sent to the secretary of state of tennessee as required by t ennessee code

*2015 training manual church of god in christ* - May 01 2023

web this manual was compiled with the assistance of dr doreatha fields assistant dean and a diverse group o f experienced ministry tested leaders of the national adjutancy this training manual is organized to provide in depth training on the three major tenets of the adjutancy corp 1 ceremony 2 liturgy and 3 protocol

*church of god in christ wikipedia* - Nov 26 2022

web church of god in christ wikipedia the church of god in christ cogic is an international holiness pentecostal christian denomination 2 4 and the largest pentecostal denomination in the united states 5

**cogic justice** - Dec 28 2022

web cogic justice

*official manual for the missionary and auxiliary awareness* - Feb 15 2022

web official manual for the missionary and auxiliary awareness institute cogic after 1991 date created and or issued after 1991 publication information church of god in christ headquarters jurisdiction department of women examining board memphis tennessee university of southern california libraries

*table of contents* - Sep 24 2022

web official manual of the church of god in christ seventh edition revised 1957 published by the authorization and approval of bishop c h mason senior bishop and founder of the church of god in christ this discipline is subject to being revised annually by the general assembly compilation and editorial commission

*official handbook for department of women new and updated* - Apr 19 2022

web reviews the department of women handbook revised edition replaces all previous editions this handbook provides extensive information pertaining to the origin development work and growth of the department of

**church of god in christ inc general council of pastors and** - May 21 2022

web official handbook governing rules and regulations produced by and with the authority and approval of the chairman officers and members of the general council of pastors and elders the editor and publisher of the official governing rules and regulations of the general

*home church of god in christ* - Oct 26 2022

web cogic world mission cogic world missions is the global missions of the church of god in christ click here the whole truth check out cogic s 1 urban christian magazine today click here learn more

**cogic official manual complete** - Oct 06 2023

web of the official manual of the church of god in christ several decades have passed since the publication of our first manual which was last amended in 1952 the tremendous expansion of the church throughout the world with its accelerated growth and many resulting changes necessitated a more complete and comprehensive manual

**church of god in christ official manual by cogic publishing** - Mar 31 2023

web dec 15 2013 the church of god in christ official manual is an informative doctrinal and disciplinary handbook gives guidelines for conduct and attire for both ministry and laity product details related subjects church congregational administration church institutions organizations general miscellaneous church church work bibles

[official handbook cogic justice](#) - Mar 19 2022

web handbook will serve as the official guide for women in ministry in the church of god in christ this newly revised edition

will replace and supersede all previous editions it presents the organizational and leadership structure contained in all preceding editions with additional information

**cogic manuals pdf version cogic justice** - Jun 02 2023

web cogic manuals pdf version click on the links to view the manuals these pdf s each have a table of contents to make navigating the files easier we are currently in the process of updating our e books to match the page numbers found in the hard copies we have started with the official manual

*church of god in christ official manual goodreads* - Jan 29 2023

web dec 3 2019 church of god in christ publishing house 3 75 4 ratings1 review the church of god in christ official manual is an informative doctrinal and disciplinary handbook gives guidelines for conduct and attire for both ministry and laity 241 pages kindle edition published december 3 2019

**cogic official manual complete pdf4pro** - Jul 23 2022

web cogic official manual complete 03 07 11 08 25 49 am1 official manual with the doctrines and discipline of the church of god in christ 1973 written by the authorization and approval of the general assembly

*official manual of the church of god in christ worldcat org* - Feb 27 2023

web official manual of the church of god in christ worldcat org author church of god in christ print book english 1957 edition 7th ed rev view all formats and editions publisher church of god in christ memphis 1957 show more information location not available we are unable to determine your location to show libraries near you

**church of god in christ** - Aug 04 2023

web for cogic churches throughout the united states and worldwide to invite their family members to church presenting to them the plan of salvation statement from introduction of the official manual the church of god in christ is one of the fastest growing denominations in the world as our name suggests we are a god centered church

[official manual with the doctrines and discipline of the church of](#) - Sep 05 2023

web official manual with the doctrines and discipline of the church of god in christ 1973 church of god in christ free download borrow and streaming internet archive by church of god in christ publication date 1991 topics church of god in christ handbooks manuals etc church of god in christ publisher

**manuals cogic adjutancy church of god in christ** - Aug 24 2022

web download the training manual from the 2019 fall academy in st louis mo it includes all of the outlines and materials provided during the class sessions

**church of god in christ official manual kindle edition** - Jul 03 2023

web dec 3 2019 the church of god in christ official manual is an informative doctrinal and disciplinary handbook gives

guidelines for conduct and attire for both ministry and laity print length 241 pages language english sticky notes on kindle  
scribe publication date december 3 2019 file size 486 kb page flip

**el invierno en el triángulo de hielo la zona más fría de españa** - Sep 06 2023

web mar 4 2022 el territorio comprendido entre teruel calamocha y molina de aragón es conocido como el triángulo de hielo  
es la zona poblada de españa dónde se han

**el triangulo de hielo teruel calamocha molina de veena das** - Dec 17 2021

**el triángulo de hielo teruel calamocha molina de aragón** - Jan 30 2023

web este libro obra del divulgador científico vicente aupí es el primer estudio climático que se publica sobre el polo del frío  
español asentado en la franja geográfica comprendida

el triángulo del lago 2000 imdb - Mar 20 2022

web as this el triangulo de hielo teruel calamocha molina de it ends going on innate one of the favored ebook el triangulo de  
hielo teruel calamocha molina de collections

el triangulo de hielo teruel calamocha molina de unai elorriaga - Jun 22 2022

web may 4 2000 el triángulo del lago directed by mauricio calderón with david mondaca jorge ortiz sánchez ximena galarza  
valeria adriazola while vacationing in the

*el triangulo de hielo teruel calamocha molina de wrbb neu* - Jul 24 2022

web el triangulo de hielo teruel calamocha molina de downloaded from protease odontocompany com by guest tyrese rich the  
construction of the self

*triangle película wikipedia la enciclopedia libre* - Jan 18 2022

el triángulo del lago wikipedia la enciclopedia libre - Feb 16 2022

*el triángulo de hielo teruel calamocha molina de* - Jul 04 2023

web el triángulo geográfico que forman teruel calamocha y molina de aragón está considerado el polo del frío español su  
singularidad climática ha deparado las

*el triangulo de hielo teruel calamocha molina de pdf* - May 22 2022

web el triángulo del lago el triángulo del lago es una película boliviana de ciencia ficción dirigida por mauricio calderón  
estrenada en 1999 y protagonizada por david mondaca

el triangulo de hielo teruel calamocha molina de copy - Apr 20 2022

web triangle titulada el triángulo en argentina y triangle en hispanoamérica y españa es una película de producción anglo australiana del año 2009 escrita y dirigida por el director

[el triángulo de hielo teruel calamocha molina](#) - Oct 27 2022

web el triangulo de hielo teruel calamocha molina de 3 3 cuzco springer the world of the undead is a vast one with many stories remaining to be told in bloodsucker tales

[el triángulo de hielo de aupí royo vicente 978 84 938724 7 2](#) - Sep 25 2022

web it will extremely ease you to see guide el triangulo de hielo teruel calamocha molina de as you such as by searching the title publisher or authors of guide you in fact want

**el triángulo del hielo teruel calamocha molina de aragón** - Apr 01 2023

web may 2 2021 2 may 2021 geografía infinita 00 40 52 charlamos con el divulgador científico vicente aupí sobre el triángulo del hielo la zona situada entre calamocha

*el triángulo de hielo la zona más fría de españa* - May 02 2023

web an edition of el triángulo de hielo teruel calamocha molina de aragón 2013

*noches tropicales en teruel el triángulo de hielo es* - Jun 03 2023

web el triángulo de hielo teruel calamocha molina de aragón estudio climático del polo del frío español compartir en vicente aupí 0 comentarios comenta y valora este

**el triángulo de hielo teruel calamocha molina de** - Feb 28 2023

web el triángulo de hielo teruel calamocha molina de aragón estudio climático del polo del frío español aupí royo vicente amazon com tr kitap

*el triángulo de hielo geografía infinita podcast podtail* - Dec 29 2022

web el triángulo geográfico que forman teruel calamocha y molina de aragón está considerado el polo del frío español la singularidad climática de esta zona del

*el triángulo de hielo donde los termómetros bajan de* - Oct 07 2023

web el triángulo de hielo donde los termómetros bajan de 20º al menos una vez por década molina de aragón guadalajara calamocha teruel y la propia teruel capital

**el triángulo de hielo así es el rincón más frío de españa** - Aug 05 2023

web may 17 2021 dónde está el triángulo de hielo el triángulo de hielo está asentado en la franja geográfica comprendida entre teruel calamocha y molina de aragón allí se

**el triángulo de hielo teruel calamocha molina de aragón** - Aug 25 2022

web 2 el triangulo de hielo teruel calamocha molina de 2022 01 21 general chapters discussing the climate the biogeography

and the flora and a second section with

[el triángulo de hielo teruel calamocho molina de aragón](#) - Nov 27 2022

web sep 19 2023 el triángulo de hielo teruel calamocho molina de aragón estudio climático del polo del frío español by vicente aupí royo noches tropicales en teruel

[pdf the mauser m91 through m98 bolt actions a shop](#) - Apr 29 2022

web jan 1 1990 a detailed book which is extremely practical for every level of gunsmithing knowledge this manual covers the 1911 from the lanyard loop to the barrel bushing

**the u s m1911 m1911a1 pistols and commercial m1911 type** - Oct 24 2021

[the mauser m91 through m98 bolt actions a shop manual](#) - Aug 02 2022

web the s w revolver a shop manual vsp publishers 1990 paperback 8vo very good item 73665 153pp text unmarked to crisp white pages full of b w photos binding

*the colt 45 automatic a shop manual volume 1* by - Dec 06 2022

web may 11 2016 jerry kuhnhausen s 1911 shop manual 8596 views 27 replies 22 participants last post by libertexan may 13 2016 jump to latest a acpie360

[jerry kuhnhausen the us m 1911 m 1911 a 1 pistols a shop](#) - Mar 29 2022

web jan 1 1997 with kuhnhausen s original volume 1 and the new volume 2 you have in hand more practical m1911 info tech data than ever before published in the entire

[the colt 45 automatic a shop manual kuhnhausen jerry](#) - Nov 24 2021

[jerry kuhnhausen abebooks](#) - Jan 07 2023

web jerry kuhnhausen publication date 1991 topics gunsmithing firearms gun rifle manual shop manual collection manuals contributions manuals additional collections shop

**the s w revolver a shop manual jerry kuhnhausen** - Feb 25 2022

web product overview the expanded 5th edition covers the traditional prewar post war s w hand ejector models and basically traditional s w numbered models made through

**home heritage gun books** - May 11 2023

web midwayusa is proud to offer the following shop manuals by jerry kuhnhausen the colt 45 automatic the u s m1911 1911a1 the colt single actions revolvers

**amazon com jerry kuhnhausen books** - Jul 13 2023



web jan 1 1990 jerry kuhnhausen s book the s w revolver a shop manual is an exceptionally detailed book on the j k l and n frame s w revolver actions whew

**the s w revolver a shop manual covers the s w j** - Mar 09 2023

web jerry kuhnhausen has 48 books on goodreads with 153 ratings jerry kuhnhausen s most popular book is colt 45 automatic a shop manual

**amazon com jerry kuhnhausen shop manuals books** - Aug 14 2023

web heritage gun books publishes and distributes the world s best gunsmithing manuals the jerry kuhnhausen vsp gunsmithing gun repair and gun rebuilding manuals

*jerry kuhnhausen shop manual by helenmcgee3835 issuu* - Jan 27 2022

**jerry kuhnhausen the us m 1911 m 1911 a 1 pistols** - Jun 12 2023

web the 45 automatic new expanded 10th edition volume 1 jerry kuhnhausen shop manual series volume 1 10th edition

**books by jerry kuhnhausen author of colt 45 automatic** - Oct 04 2022

web oct 28 2022 a shop manual by jerry kuhnhausen in pdf format complete free brief summary of book the mauser m91 through m98 bolt actions a shop manual by

**jerry kuhnhausen 1911 shop manual pdf** - Dec 26 2021

[jerry kuhnhausen manuals artisan ideas](#) - Sep 03 2022

web note many internet archive torrents contain a pad file directory this directory and the files within it may be erased once retrieval completes note the file jerry kuhnhausen the us

**jerry kuhnhausen s 1911 shop manual 1911forum** - Jul 01 2022

web aug 8 2017 get jerry kuhnhausen shop manual pdf file for free from our online library related pdfs for jerry kuhnhausen shop manual jerry kuhnhausen shop

*the s w revolvers a shop manual new expanded 5th* - Feb 08 2023

web the colt 45 automatic vol 1 dvd gunsmithing the colt 45 auto m1911 m1911a1 book dvd by j kuhnhausen price 65 90 quantity add to cart the colt 45

[the colt single action revolvers a shop manual volumes i ii](#) - Nov 05 2022

web mar 7 2022 go to parent directory ia thumb jpg 21 jul 2022 03 29 16 7k jerry kuhnhausen the us m 1911 m 1911 a 1 pistols a shop manual heritage gun books

**amazon com jerry kuhnhausen shop manuals** - Apr 10 2023

web bibliographic information title the colt single action revolvers a shop manual volumes i ii author jerry kuhnhausen editor noel kuhnhausen publisher heritage gun

**the s w revolver a shop manual 5th edition by jerry** - Sep 22 2021

*jerry kuhnhausen the us m 1911 m 1911 a 1 pistols a shop* - May 31 2022

web m type pistols a shop manual volume 2 by jerry kuhnhausen a shop manual volume 1 in the kuhnhausen m pistol series  
jerry kuhnhausen mk iv series 80