

## Mono-Jetronic

### Relación general sistema

El Mono-Jetronic es un sistema de inyección centralizada de baja presión gobernado electrónicamente, para motores de cuatro cilindros, con una válvula de inyección electromagnética en disposición central, contrariamente a una válvula de inyección por cada cilindro en los sistemas de inyección individual KE-Jetronic y L-Jetronic.

La principal pieza del sistema Mono-Jetronic es el grupo de inyección (que se describirá en lo sucesivo) con una válvula de inyección electromagnética que inyecta intermitentemente el

combustible (interrumpiéndose a intervalos) por encima de la mariposa.

La distribución del combustible entre los diversos cilindros se realiza mediante el tubo de admisión.

Diversas sondas de medición (sensores) determinan todas las magnitudes de servicio esenciales del motor que son necesarias para una adaptación óptima de la mezcla. Las magnitudes de entrada son p. ej.:

- Angulo de la mariposa.
- Número de revoluciones del motor.
- Temperatura del motor y del aire aspirado.
- Posición de ralentí/plena carga de la mariposa.
- Contenido residual de oxígeno en los gases de escape y (según el equipamiento del vehículo):

Figura 1

Relación general del sistema Mono-Jetronic.

1 Depósito de combustible, 2 Electrobomba de combustible, 3 Filtro de combustible, 4 Regulador de presión, 5 Válvula de inyección electromagnética, 6 Sensor de temperatura del aire, 7 Aparato de mando electrónico, 8 Actuador de la mariposa, 9 Potenciometro de la mariposa, 10 Válvula regeneradora, 11 Depósito de carbón activo, 12 Sonda Lambda, 13 Sensor de temperatura del motor, 14 Distribuidor de encendido, 15 Batería, 16 Conmutador de encendido y arranque, 17 Relé, 18 Conexión de diagnóstico, 19 Grupo de inyección.

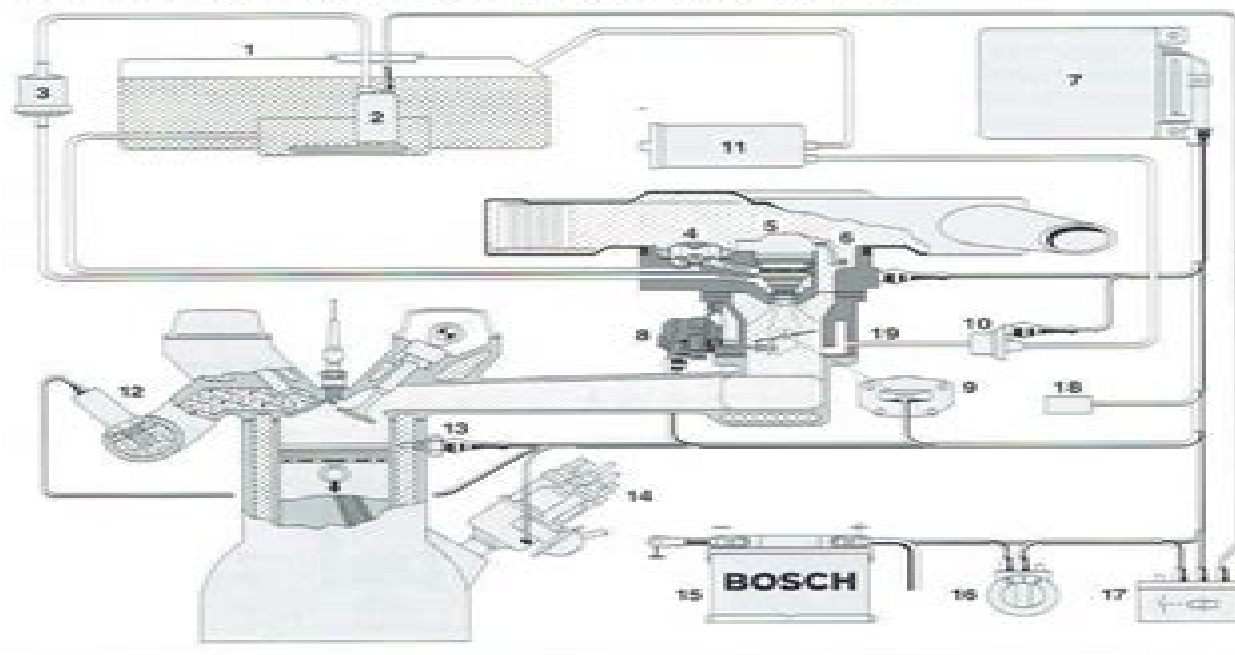

# Bosch Mono Jetronic Manual

**Robert R. Redfield**



## **Bosch Mono Jetronic Manual:**

*Manual de la técnica del automóvil* Karl-Heinz Dietsche, 2005 Conocimientos técnicos de automoción La 4 edición ha sido revisada por completo Extracto de los nuevos contenidos Mando de los motores Otto reestructurado y actualizado Sistemas de estabilización del vehículo para turismos con nuevas funciones de ABS y del programa electrónico de estabilidad ESP Sistemas de asistencia al conductor Dinámica transversal del vehículo base del programa electrónico de estabilidad ESP Diagnóstico de a bordo OBD Fundamentos legales y realización Gestión electrónica de frenos en los vehículos industriales como plataforma para sistemas de asistencia al conductor Dinámica transversal del vehículo base del programa electrónico de estabilidad ESP Diagnóstico de a bordo OBD fundamentos legales y realización Gestión electrónica de frenos en los vehículos industriales como plataforma para sistemas de asistencia al conductor Transmisión analógica y digital de series Sistemas multimedia Todos de desarrollo y procedimientos herramientas para el desarrollo de hardware y software diseño del sonido y detalles aerodinámicos para vehículos Gestión medioambiental Manual de la técnica del automóvil, 1999

Chilton's Import Car Repair Manual, 1986, 1985 Manual Técnico del Automóvil Jorge Lucendo, 2019-08-21 El automóvil forma parte de nuestras vidas y según un estudio realizado en el 2016 pasamos unas 25 000 horas conduciendo que son unos 3 años de nuestra vida El coche es nuestro medio de vida pues gracias a él podemos hacer realizar una vida social plena gracias a él podemos acceder a nuestro medio de vida que es el trabajo y en ningún momento podemos prescindir de este medio de locomoción En este libro se explica uno por uno todos los medios y todos los avances tecnológicos que ha experimentado el automóvil desde un principio hasta nuestros días explicando el vehículo en general con todo tipo de detalles motores sistemas de frenado sistemas de seguridad en definitiva todos los componentes del automóvil incluyendo todos los avances tecnológicos en la industria del automóvil todo ello ilustrado con 180 imágenes **Automotive Computers and Digital Instrumentation** Robert N. Brady, 1988 Forthcoming Books Rose Arny, 1996-06 **Ward's Auto World**, 1982 **Books In Print 2004-2005** Ed Bowker Staff, Staff Bowker, Ed, 2004 **Ward's Automotive Yearbook**, 1983 Includes advertising matter *Motor Industry Management*, 1999-02 MIRA Automobile Abstracts Motor Industry Research Association, 1984 **Mono-Jetronic** Anton Beer, 1997 *Highway Research Abstracts*, 1991 Popular Mechanics, 1982-06 Popular Mechanics inspires instructs and influences readers to help them master the modern world Whether it's practical DIY home improvement tips gadgets and digital technology information on the newest cars or the latest breakthroughs in science PM is the ultimate guide to our high tech lifestyle *D-Jetronic Service Manual* Robert Bosch GmbH., 1975 *Whitaker's Books in Print*, 1998 **Popular Mechanics**, 1982-06 Popular Mechanics inspires instructs and influences readers to help them master the modern world Whether it's practical DIY home improvement tips gadgets and digital technology information on the newest cars or the latest breakthroughs in science PM is the ultimate guide to our high tech lifestyle *The AOPA Pilot*, 1996 **Autocar & Motor**, 1992-07 **World Cars 1980** Automobile Club of Italy, 1980

Delve into the emotional tapestry woven by Crafted by in **Bosch Mono Jetronic Manual** . This ebook, available for download in a PDF format ( \*), is more than just words on a page; it is a journey of connection and profound emotion. Immerse yourself in narratives that tug at your heartstrings. Download now to experience the pulse of each page and let your emotions run wild.

[https://yousky7.com/data/uploaded-files/HomePages/chevy\\_4\\_speed\\_manual\\_transmission\\_rebuild.pdf](https://yousky7.com/data/uploaded-files/HomePages/chevy_4_speed_manual_transmission_rebuild.pdf)

## **Table of Contents Bosch Mono Jetronic Manual**

1. Understanding the eBook Bosch Mono Jetronic Manual
  - The Rise of Digital Reading Bosch Mono Jetronic Manual
  - Advantages of eBooks Over Traditional Books
2. Identifying Bosch Mono Jetronic Manual
  - Exploring Different Genres
  - Considering Fiction vs. Non-Fiction
  - Determining Your Reading Goals
3. Choosing the Right eBook Platform
  - Popular eBook Platforms
  - Features to Look for in an Bosch Mono Jetronic Manual
  - User-Friendly Interface
4. Exploring eBook Recommendations from Bosch Mono Jetronic Manual
  - Personalized Recommendations
  - Bosch Mono Jetronic Manual User Reviews and Ratings
  - Bosch Mono Jetronic Manual and Bestseller Lists
5. Accessing Bosch Mono Jetronic Manual Free and Paid eBooks
  - Bosch Mono Jetronic Manual Public Domain eBooks
  - Bosch Mono Jetronic Manual eBook Subscription Services
  - Bosch Mono Jetronic Manual Budget-Friendly Options

6. Navigating Bosch Mono Jetronic Manual eBook Formats
  - ePub, PDF, MOBI, and More
  - Bosch Mono Jetronic Manual Compatibility with Devices
  - Bosch Mono Jetronic Manual Enhanced eBook Features
7. Enhancing Your Reading Experience
  - Adjustable Fonts and Text Sizes of Bosch Mono Jetronic Manual
  - Highlighting and Note-Taking Bosch Mono Jetronic Manual
  - Interactive Elements Bosch Mono Jetronic Manual
8. Staying Engaged with Bosch Mono Jetronic Manual
  - Joining Online Reading Communities
  - Participating in Virtual Book Clubs
  - Following Authors and Publishers Bosch Mono Jetronic Manual
9. Balancing eBooks and Physical Books Bosch Mono Jetronic Manual
  - Benefits of a Digital Library
  - Creating a Diverse Reading Collection Bosch Mono Jetronic Manual
10. Overcoming Reading Challenges
  - Dealing with Digital Eye Strain
  - Minimizing Distractions
  - Managing Screen Time
11. Cultivating a Reading Routine Bosch Mono Jetronic Manual
  - Setting Reading Goals Bosch Mono Jetronic Manual
  - Carving Out Dedicated Reading Time
12. Sourcing Reliable Information of Bosch Mono Jetronic Manual
  - Fact-Checking eBook Content of Bosch Mono Jetronic Manual
  - Distinguishing Credible Sources
13. Promoting Lifelong Learning
  - Utilizing eBooks for Skill Development
  - Exploring Educational eBooks
14. Embracing eBook Trends
  - Integration of Multimedia Elements

- 
- Interactive and Gamified eBooks

## **Bosch Mono Jetronic Manual Introduction**

Free PDF Books and Manuals for Download: Unlocking Knowledge at Your Fingertips In today's fast-paced digital age, obtaining valuable knowledge has become easier than ever. Thanks to the internet, a vast array of books and manuals are now available for free download in PDF format. Whether you are a student, professional, or simply an avid reader, this treasure trove of downloadable resources offers a wealth of information, conveniently accessible anytime, anywhere. The advent of online libraries and platforms dedicated to sharing knowledge has revolutionized the way we consume information. No longer confined to physical libraries or bookstores, readers can now access an extensive collection of digital books and manuals with just a few clicks. These resources, available in PDF, Microsoft Word, and PowerPoint formats, cater to a wide range of interests, including literature, technology, science, history, and much more. One notable platform where you can explore and download free Bosch Mono Jetronic Manual PDF books and manuals is the internet's largest free library. Hosted online, this catalog compiles a vast assortment of documents, making it a veritable goldmine of knowledge. With its easy-to-use website interface and customizable PDF generator, this platform offers a user-friendly experience, allowing individuals to effortlessly navigate and access the information they seek. The availability of free PDF books and manuals on this platform demonstrates its commitment to democratizing education and empowering individuals with the tools needed to succeed in their chosen fields. It allows anyone, regardless of their background or financial limitations, to expand their horizons and gain insights from experts in various disciplines. One of the most significant advantages of downloading PDF books and manuals lies in their portability. Unlike physical copies, digital books can be stored and carried on a single device, such as a tablet or smartphone, saving valuable space and weight. This convenience makes it possible for readers to have their entire library at their fingertips, whether they are commuting, traveling, or simply enjoying a lazy afternoon at home. Additionally, digital files are easily searchable, enabling readers to locate specific information within seconds. With a few keystrokes, users can search for keywords, topics, or phrases, making research and finding relevant information a breeze. This efficiency saves time and effort, streamlining the learning process and allowing individuals to focus on extracting the information they need. Furthermore, the availability of free PDF books and manuals fosters a culture of continuous learning. By removing financial barriers, more people can access educational resources and pursue lifelong learning, contributing to personal growth and professional development. This democratization of knowledge promotes intellectual curiosity and empowers individuals to become lifelong learners, promoting progress and innovation in various fields. It is worth noting that while accessing free Bosch Mono Jetronic Manual PDF books and manuals is convenient and cost-effective, it is vital to respect copyright laws and intellectual property rights. Platforms offering free downloads often operate within legal boundaries,

ensuring that the materials they provide are either in the public domain or authorized for distribution. By adhering to copyright laws, users can enjoy the benefits of free access to knowledge while supporting the authors and publishers who make these resources available. In conclusion, the availability of Bosch Mono Jetronic Manual free PDF books and manuals for download has revolutionized the way we access and consume knowledge. With just a few clicks, individuals can explore a vast collection of resources across different disciplines, all free of charge. This accessibility empowers individuals to become lifelong learners, contributing to personal growth, professional development, and the advancement of society as a whole. So why not unlock a world of knowledge today? Start exploring the vast sea of free PDF books and manuals waiting to be discovered right at your fingertips.

### **FAQs About Bosch Mono Jetronic Manual Books**

How do I know which eBook platform is the best for me? Finding the best eBook platform depends on your reading preferences and device compatibility. Research different platforms, read user reviews, and explore their features before making a choice. Are free eBooks of good quality? Yes, many reputable platforms offer high-quality free eBooks, including classics and public domain works. However, make sure to verify the source to ensure the eBook credibility. Can I read eBooks without an eReader? Absolutely! Most eBook platforms offer web-based readers or mobile apps that allow you to read eBooks on your computer, tablet, or smartphone. How do I avoid digital eye strain while reading eBooks? To prevent digital eye strain, take regular breaks, adjust the font size and background color, and ensure proper lighting while reading eBooks. What the advantage of interactive eBooks? Interactive eBooks incorporate multimedia elements, quizzes, and activities, enhancing the reader engagement and providing a more immersive learning experience. Bosch Mono Jetronic Manual is one of the best book in our library for free trial. We provide copy of Bosch Mono Jetronic Manual in digital format, so the resources that you find are reliable. There are also many Ebooks of related with Bosch Mono Jetronic Manual. Where to download Bosch Mono Jetronic Manual online for free? Are you looking for Bosch Mono Jetronic Manual PDF? This is definitely going to save you time and cash in something you should think about.

### **Find Bosch Mono Jetronic Manual :**

**chevy 4 speed manual transmission rebuild**

~~chevrolet metro repair manual~~

**chevrolet 2006 mustang users manual**

[chevrolet k1500 4wd service manual](#)

[cherry py essentials rapid python web application development hellegouarch sylvain](#)

[chevrolet spark 2006 repair manual](#)

**cherokee 98 manual**

[chevy 3500 manual](#)

[chevrolet malibu 1997 2015 factory service repair manual](#)

**chevy 305 spark plug to distributor wiring diagram**

[chevrolet express stereo wiring](#)

[chevy 3500 van owners manual 2004](#)

[chemquest intro to chemical reactions answer key](#)

[chevy aveo 2007 2009 service repair manual](#)

[cherokee casino jobs in oklahoma](#)

## **Bosch Mono Jetronic Manual :**

SAMHSA's National Helpline Jun 9, 2023 — SAMHSA's National Helpline is a free, confidential, 24/7, 365-day-a-year treatment referral and information service (in English and Spanish) ... Staying Sober: A Guide for Relapse Prevention Mr. Gorski is the author of numerous books, audio, and video tapes, including Passages Through Recovery -- An Action Plan for Preventing Relapse, Staying Sober ... Hazelden Store: Staying Sober In Staying Sober the authors discuss addictive disease and its physical, psychological, and social effects. They also identify sobriety-based symptoms, ... Staying Sober: A Guide for Relapse Prevention Staying Sober explains addictive disease, Post Acute Withdrawal (PAW), recovery and partial recovery, mistaken beliefs about recovery and relapse, the relapse ... Staying Sober Terence Gorski Sober On A Drunk Planet: 3 Sober Steps. An Uncommon Guide To Stop Drinking and Master Your Sobriety (Quit Lit Sobriety Series). by Sean Alexander. Staying Sober: A Guide for Relapse Prevention Read 18 reviews from the world's largest community for readers. Very good. Scuffed edges and some on cover. Small crease across back upper corner. Few dog-... Staying Sober: A Guide for Relapse Prevention CEU course for Addiction Counselors and Social Workers Staying Sober A Guide for Relapse Prevention; This book is a great resource for understanding and ... Staying sober : a guide for relapse prevention. Staying sober : a guide for relapse prevention. Gorski, Terence T. (Author). Miller, Merlene. (Added ... List of books by author Terence T. Gorski Staying Sober: A Guide for Relapse Prevention 083090459X Book Cover · Passages Through Recovery: An Action Plan for Preventing Relapse 1568381395 Book Cover. Staying sober : a guide for relapse prevention Staying sober : a guide for relapse prevention Available at Andrew L. Bouwhuis Library Book Shelves (RC565 .G68 1986) ... Libretto d'uso e Manutenzione



online per la tua MINI Il libretto Uso e manutenzione online rappresenta la versione più aggiornata per la tua MINI ... JOHN COOPER WORKS. John ... Manuali Uso e Manutenzione - MINIMINOR.COM Disponibili i manuali d'Uso e Manutenzione per la propria Innocenti Mini Minor e Mini Cooper. Sono disponibili anche per i modelli di Mini più recenti di ... MINI Driver's Guide 4+ - App Store La Driver's Guide è un libretto Uso e manutenzione specifico\* per modelli MINI selezionati\*\*. Per visualizzare il documento la prima volta è necessario un ... Manuale uso e manutenzione MINI 3-5 porte (ITA) Sep 16, 2021 — Manuale di uso e manutenzione per MINI F55-F56 in lingua italiana (©BMW Group) Manuali e istruzioni per auto Mini Libretto Uso E Manutenzione Mini Cooper. Di seconda mano: Privato. EUR 28,00. 0 offerte · Scadenza: 18 dic., alle 16:48 ... MINI Owners and Service Manual Need to see the owner manuals for your MINI? Find a PDF manual or use our interactive online manual to search and view instructional videos & FAQs. Manuali di assistenza e riparazione Mini Cooper per l'auto Trova una vasta selezione di Manuali di assistenza e riparazione Mini Cooper per l'auto a prezzi vantaggiosi su eBay. Scegli la consegna gratis per ... Manuali di riparazione per MINI e video tutorial. Libretto di istruzioni MINI gratuito · Manuale uso e manutenzione MINI online · Manuale officina MINI pdf · Manuale tecnico d'officina MINI scaricare · Libretto uso ... MINI Driver's Guide - App su Google Play La Driver's Guide è un libretto Uso e manutenzione specifico\* per modelli MINI selezionati\*\*. Per visualizzare il documento la prima volta è necessario un ... Innocenti Mini Cooper 1300 - Manuale D'uso e ... - Scribd Manual de uso del Innocenti Mini Cooper 1300 en italiano by daloppel. Chapter 27: Bacteria and Archaea The chapter opens with amazing tales of life at the extreme edge. What are the "masters of adaptation"? Describe the one case you thought most dramatic. Chapter 27: Bacteria and Archaea Genome. Membranes. Location of genome. Plasmids. Ribosomes. Page 3. AP Biology Reading Guide. Chapter 27: Bacteria and Archaea. Fred and Theresa Holtzclaw. Ap Biology Chapter 27 Reading Guide Answers - Fill Online ... Fill Ap Biology Chapter 27 Reading Guide Answers, Edit online. Sign, fax and printable from PC, iPad, tablet or mobile with pdfFiller ☐ Instantly. Try Now! Chapter 27 Reading Guide Flashcards Study with Quizlet and memorize flashcards containing terms like Which two domains include prokaryote?, Are prokaryotes multicellular or unicellular?, ... AP Bio chapter 27 reading Guide Flashcards Study with Quizlet and memorize flashcards containing terms like What are the masters of adaptation ? What is one example?, Which two domains include ... AP Biology Reading Guide Chapter 51: Animal Behavior ... 27. This concept looks at some very interesting ways that genetic changes affect behavior. Several important case studies that show a genetic component to ... Campbell 8th Edition Reading Gui Campbell 8th edition Reading Guides Fred and Theresa Holtzclaw Campbell Biology 8th Edition Chapter ... Chapter 27 Prokaryotes · Chapter 45 Endocrine System. AP Biology Summer Assignment: 2016-2017 Begin your study of biology this year by reading Chapter 1. It will serve as ... AP Biology Reading Guide. Fred and Theresa Holtzclaw. Chapter 3: Water and the ... Campbell Biology Chapter 27 (powell\_h) Flashcards Study Campbell Biology Chapter 27 (powell\_h) flashcards taken from chapter 27 of the book Campbell Biology. Biology in Focus - Chapter 27 | PPT Apr 21, 2016 — Biology in Focus -

---

Chapter 27 - Download as a PDF or view online for free.