

# Dell™ Latitude™ E6410 /E6410 ATG

## Setup and Features Information

### Latitude E6410 — Front View

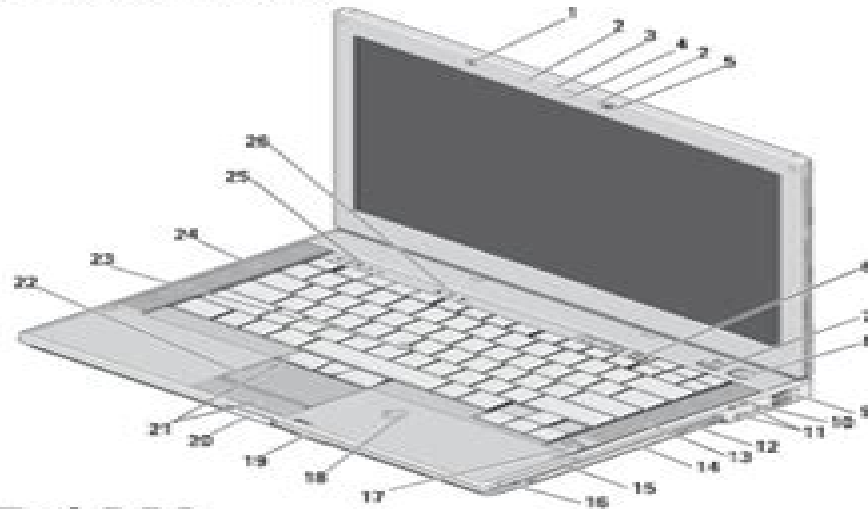

**DELL™**

Regulatory Model: P92DLA Regulatory Type: P92DLAM1

## About Warnings



**WARNING:** A WARNING indicates a potential for property damage, personal injury, or death.

- |                                  |   |
|----------------------------------|---|
| 1 Ambient Light Sensor (ALS)     | 2 stereo microphones (optional)             |
| 3 camera LED (optional)          | 4 camera (optional)                         |
| 5 display latch                  | 6 volume control buttons                    |
| 7 Dell Latitude ON™ button       | 8 power button                              |
| 9 USB 2.0 connectors (2)         | 10 wireless switch                          |
| 11 audio connectors              | 12 CD/DVD/Blu-ray disc removal button       |
| 13 right speaker                 | 14 CD/DVD/Blu-ray disc drive                |
| 15 PC card or Express card slot  | 16 IEEE 1394 connector                      |
| 17 fingerprint reader (optional) | 18 contactless smart card reader (optional) |
| 19 Secure Digital (SD) card slot | 20 display latch release button             |
| 21 touchpad/trackstick buttons   | 22 touchpad                                 |
| 23 trackstick                    | 24 left speaker                             |
| 25 device status lights          | 26 keyboard status lights                   |

January 2010

### Latitude E6410 — Back View

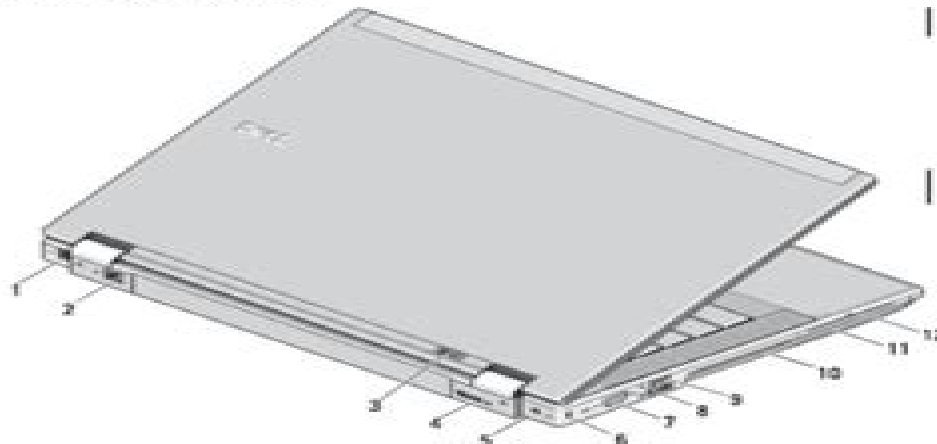

- |  |
|--|
| 1 modem connector (Optional modem daughter card) |
| 2 network connector                              |
| 3 power/battery indicators                       |
| 4 multimode DisplayPort connector                |
| 5 AC adapter connector                           |
| 6 security cable slot                            |
| 7 video connector (VGA)                          |
| 8 e-SATA/USB 2.0 connector                       |
| 9 powered USB 2.0 connector                      |
| 10 cooling vent                                  |
| 11 hard drive                                    |
| 12 smart card slot                               |



**WARNING:** Do not block, push objects into, or allow dust to accumulate in the air vents. Do not store your Dell computer in a low-airflow environment, such as a closed briefcase, while it is running. Restricting the airflow can damage the computer or cause a fire. The computer turns on the fan when the computer gets hot. Fan noise is normal and does not indicate a problem with the fan or the computer.

# Dell Latitude Manual

**John L. Andriot, Donna Andriot**



## **Dell Latitude Manual:**

**CompTIA A+ Complete Study Guide** Quentin Docter, Emmett Dulaney, Toby Skandier, 2007-02-03 All in one guide prepares you for CompTIA's new A Certification Candidates aiming for CompTIA's revised two exam A Certified Track will find everything they need in this value packed book Prepare for the required exam CompTIA A Essentials 220 601 as well as your choice of one of three additional exams focusing on specific job roles IT Technician 220 602 Remote Support Technician 220 603 or Depot Technician 220 604 This in depth book prepares you for any or all four exams with full coverage of all exam objectives Inside you'll find Comprehensive coverage of all exam objectives for all four exams in a systematic approach so you can be confident you're getting the instruction you need Hand on exercises to reinforce critical skills Real world scenarios that show you life beyond the classroom and put what you've learned in the context of actual job roles Challenging review questions in each chapter to prepare you for exam day Exam Essentials a key feature at the end of each chapter that identifies critical areas you must become proficient in before taking the exams A handy fold out that maps every official exam objective to the corresponding chapter in the book so you can track your exam prep objective by objective Look inside for complete coverage of all exam objectives for all four CompTIA A exams Featured on the CD SYBEX TEST ENGINE Test your knowledge with advanced testing software Includes all chapter review questions and 8 total practice exams ELECTRONIC FLASHCARDS Reinforce your understanding with flashcards that can run on your PC Pocket PC or Palm handheld Also on CD you'll find the entire book in searchable and printable PDF Study anywhere any time and approach the exam with confidence Visit [www.sybex.com](http://www.sybex.com) for all of your CompTIA certification needs Note CD ROM DVD and other supplementary materials are not included as part of eBook file *Mike Meyers' CompTIA A+ Guide to Managing and Troubleshooting PCs Lab Manual, Sixth Edition (Exams 220-1001 & 220-1002)* Mike Meyers, Mark Edward Soper, 2019-07-05 Publisher's Note Products purchased from Third Party sellers are not guaranteed by the publisher for quality authenticity or access to any online entitlements included with the product 140 Hands On Step by Step Labs Fully Updated for the Core 1 and Core 2 Exams This practical workbook contains more than 140 labs that challenge you to solve real world problems by applying key concepts Thoroughly revised for the 220 1001 and 200 1002 exam objectives this book maps directly to Mike Meyers' *CompTIA A Guide to Managing and Troubleshooting PCs Sixth Edition* You will get complete materials lists setup instructions and start to finish lab scenarios Hint and Warning icons guide you through tricky situations and post lab questions measure your knowledge This manual covers Hardware and OS Troubleshooting Professional Behavior Windows 7 8 1 10 Configuration and Maintenance macOS and Linux Configuration and Maintenance CPUs and RAM BIOS and UEFI Firmware Motherboards Expansion Cards and Ports Power Supplies and Mass Storage PC Assembly and Configuration Users Groups and Permissions Display Technologies Local Area and Wi-Fi Networking The Internet Computer Security and more

**InfoWorld**, 1994-05-16 InfoWorld is targeted to Senior IT professionals Content is segmented into Channels and Topic

Centers InfoWorld also celebrates people companies and projects [CompTIA A+ Complete Deluxe Study Guide Recommended Courseware](#) Quentin Docter, Emmett Dulaney, Toby Skandier, 2012-09-20 Everything you need to prepare for the CompTIA A exams CompTIA A is the most sought after certification for PC technicians This guide covers every aspect of the required exams 220 801 and 220 802 Fully updated to cover the latest best practices current software and hardware and mobile OSes this Deluxe guide also includes an exclusive bonus CD featuring additional practice exams flashcards instructional videos and the entire e book in ePDF eMobi and ePub versions Includes a coupon for 10% Off CompTIA Certification Exams Fully updated to cover the latest exams and exam objectives Covers personal computer components laptops and portable devices operating systems printers and scanners networks security safety and environmental issues communication and professionalism Bonus CD features the Sybex Test Engine with additional practice exams twice the electronic flashcards as the Standard edition and eMobi ePub and ePDF versions of the book **CompTIA A Complete Deluxe Study Guide 2nd Edition** is a complete test prep guide that will help you pass the A exam with confidence **Manual of Seamanship for the Officer of the Deck : Ship Under Sail Alone** P. W. Hourigan, 1903 [A Manual of Civil Engineering](#) William John Macquorn Rankine, 1872 [Computer Buyer's Guide and Handbook](#) , 1994 *A Manual of the Public Schools of Lake Mills, Wisconsin* Lake Mills (Wis.). Board of Education, 1909 *The Manual of Dates: a Dictionary of Reference to the Most Important Events in the History of Mankind* George Henry Townsend, 1874 **How to earn the merit grant, an elementary manual of school management** Henry Major, 1883 [InfoWorld](#) , 1996-06-24 InfoWorld is targeted to Senior IT professionals Content is segmented into Channels and Topic Centers InfoWorld also celebrates people companies and projects **InfoWorld** , 1995-10-02 InfoWorld is targeted to Senior IT professionals Content is segmented into Channels and Topic Centers InfoWorld also celebrates people companies and projects **Instructor Edition** Andrews, 2005-04 **PC Mag** , 1998-08 PCMag com is a leading authority on technology delivering Labs based independent reviews of the latest products and services Our expert industry analysis and practical solutions help you make better buying decisions and get more from technology [Windows Magazine](#) , 1997 **PC Magazine** , 1998 [The Software Encyclopedia](#) , 1986 [Guide to U.S. Government Publications](#) John L. Andriot, Donna Andriot, 1976 **Understanding and Using the Internet** McLaren, 1998 This effective book teaches users the fundamental skills and knowledge needed to quickly master and use the Internet Users get a complete understanding of the concepts behind the Internet as a tool and are provided with Guided Activities to get them actually using it *PC/Computing* , 1999-04

## **Dell Latitude Manual** Book Review: Unveiling the Magic of Language

In a digital era where connections and knowledge reign supreme, the enchanting power of language has become much more apparent than ever. Its ability to stir emotions, provoke thought, and instigate transformation is truly remarkable. This extraordinary book, aptly titled "**Dell Latitude Manual**," published by a very acclaimed author, immerses readers in a captivating exploration of the significance of language and its profound impact on our existence. Throughout this critique, we shall delve into the book's central themes, evaluate its unique writing style, and assess its overall influence on its readership.

<https://yousky7.com/files/browse/fetch.php/advanced%20methods%20for%20why%20ai%20for%20teachers%20guide.pdf>

### **Table of Contents Dell Latitude Manual**

1. Understanding the eBook Dell Latitude Manual
  - The Rise of Digital Reading Dell Latitude Manual
  - Advantages of eBooks Over Traditional Books
2. Identifying Dell Latitude Manual
  - Exploring Different Genres
  - Considering Fiction vs. Non-Fiction
  - Determining Your Reading Goals
3. Choosing the Right eBook Platform
  - Popular eBook Platforms
  - Features to Look for in an Dell Latitude Manual
  - User-Friendly Interface
4. Exploring eBook Recommendations from Dell Latitude Manual
  - Personalized Recommendations
  - Dell Latitude Manual User Reviews and Ratings
  - Dell Latitude Manual and Bestseller Lists

5. Accessing Dell Latitude Manual Free and Paid eBooks
  - Dell Latitude Manual Public Domain eBooks
  - Dell Latitude Manual eBook Subscription Services
  - Dell Latitude Manual Budget-Friendly Options
6. Navigating Dell Latitude Manual eBook Formats
  - ePub, PDF, MOBI, and More
  - Dell Latitude Manual Compatibility with Devices
  - Dell Latitude Manual Enhanced eBook Features
7. Enhancing Your Reading Experience
  - Adjustable Fonts and Text Sizes of Dell Latitude Manual
  - Highlighting and Note-Taking Dell Latitude Manual
  - Interactive Elements Dell Latitude Manual
8. Staying Engaged with Dell Latitude Manual
  - Joining Online Reading Communities
  - Participating in Virtual Book Clubs
  - Following Authors and Publishers Dell Latitude Manual
9. Balancing eBooks and Physical Books Dell Latitude Manual
  - Benefits of a Digital Library
  - Creating a Diverse Reading Collection Dell Latitude Manual
10. Overcoming Reading Challenges
  - Dealing with Digital Eye Strain
  - Minimizing Distractions
  - Managing Screen Time
11. Cultivating a Reading Routine Dell Latitude Manual
  - Setting Reading Goals Dell Latitude Manual
  - Carving Out Dedicated Reading Time
12. Sourcing Reliable Information of Dell Latitude Manual
  - Fact-Checking eBook Content of Dell Latitude Manual
  - Distinguishing Credible Sources
13. Promoting Lifelong Learning

- Utilizing eBooks for Skill Development
  - Exploring Educational eBooks
14. Embracing eBook Trends
- Integration of Multimedia Elements
  - Interactive and Gamified eBooks

## **Dell Latitude Manual Introduction**

In this digital age, the convenience of accessing information at our fingertips has become a necessity. Whether its research papers, eBooks, or user manuals, PDF files have become the preferred format for sharing and reading documents. However, the cost associated with purchasing PDF files can sometimes be a barrier for many individuals and organizations. Thankfully, there are numerous websites and platforms that allow users to download free PDF files legally. In this article, we will explore some of the best platforms to download free PDFs. One of the most popular platforms to download free PDF files is Project Gutenberg. This online library offers over 60,000 free eBooks that are in the public domain. From classic literature to historical documents, Project Gutenberg provides a wide range of PDF files that can be downloaded and enjoyed on various devices. The website is user-friendly and allows users to search for specific titles or browse through different categories. Another reliable platform for downloading Dell Latitude Manual free PDF files is Open Library. With its vast collection of over 1 million eBooks, Open Library has something for every reader. The website offers a seamless experience by providing options to borrow or download PDF files. Users simply need to create a free account to access this treasure trove of knowledge. Open Library also allows users to contribute by uploading and sharing their own PDF files, making it a collaborative platform for book enthusiasts. For those interested in academic resources, there are websites dedicated to providing free PDFs of research papers and scientific articles. One such website is Academia.edu, which allows researchers and scholars to share their work with a global audience. Users can download PDF files of research papers, theses, and dissertations covering a wide range of subjects. Academia.edu also provides a platform for discussions and networking within the academic community. When it comes to downloading Dell Latitude Manual free PDF files of magazines, brochures, and catalogs, Issuu is a popular choice. This digital publishing platform hosts a vast collection of publications from around the world. Users can search for specific titles or explore various categories and genres. Issuu offers a seamless reading experience with its user-friendly interface and allows users to download PDF files for offline reading. Apart from dedicated platforms, search engines also play a crucial role in finding free PDF files. Google, for instance, has an advanced search feature that allows users to filter results by file type. By specifying the file type as "PDF," users can find websites that offer free PDF downloads on a specific topic. While downloading Dell Latitude Manual free PDF files is convenient, its important to

note that copyright laws must be respected. Always ensure that the PDF files you download are legally available for free. Many authors and publishers voluntarily provide free PDF versions of their work, but its essential to be cautious and verify the authenticity of the source before downloading Dell Latitude Manual. In conclusion, the internet offers numerous platforms and websites that allow users to download free PDF files legally. Whether its classic literature, research papers, or magazines, there is something for everyone. The platforms mentioned in this article, such as Project Gutenberg, Open Library, Academia.edu, and Issuu, provide access to a vast collection of PDF files. However, users should always be cautious and verify the legality of the source before downloading Dell Latitude Manual any PDF files. With these platforms, the world of PDF downloads is just a click away.

### **FAQs About Dell Latitude Manual Books**

**What is a Dell Latitude Manual PDF?** A PDF (Portable Document Format) is a file format developed by Adobe that preserves the layout and formatting of a document, regardless of the software, hardware, or operating system used to view or print it. **How do I create a Dell Latitude Manual PDF?** There are several ways to create a PDF: Use software like Adobe Acrobat, Microsoft Word, or Google Docs, which often have built-in PDF creation tools. Print to PDF: Many applications and operating systems have a "Print to PDF" option that allows you to save a document as a PDF file instead of printing it on paper. Online converters: There are various online tools that can convert different file types to PDF. **How do I edit a Dell Latitude Manual PDF?** Editing a PDF can be done with software like Adobe Acrobat, which allows direct editing of text, images, and other elements within the PDF. Some free tools, like PDFescape or Smallpdf, also offer basic editing capabilities. **How do I convert a Dell Latitude Manual PDF to another file format?** There are multiple ways to convert a PDF to another format: Use online converters like Smallpdf, Zamzar, or Adobe Acrobats export feature to convert PDFs to formats like Word, Excel, JPEG, etc. Software like Adobe Acrobat, Microsoft Word, or other PDF editors may have options to export or save PDFs in different formats. **How do I password-protect a Dell Latitude Manual PDF?** Most PDF editing software allows you to add password protection. In Adobe Acrobat, for instance, you can go to "File" -> "Properties" -> "Security" to set a password to restrict access or editing capabilities. Are there any free alternatives to Adobe Acrobat for working with PDFs? Yes, there are many free alternatives for working with PDFs, such as: LibreOffice: Offers PDF editing features. PDFsam: Allows splitting, merging, and editing PDFs. Foxit Reader: Provides basic PDF viewing and editing capabilities. How do I compress a PDF file? You can use online tools like Smallpdf, ILovePDF, or desktop software like Adobe Acrobat to compress PDF files without significant quality loss. Compression reduces the file size, making it easier to share and download. Can I fill out forms in a PDF file? Yes, most PDF viewers/editors like Adobe Acrobat, Preview (on Mac), or



various online tools allow you to fill out forms in PDF files by selecting text fields and entering information. Are there any restrictions when working with PDFs? Some PDFs might have restrictions set by their creator, such as password protection, editing restrictions, or print restrictions. Breaking these restrictions might require specific software or tools, which may or may not be legal depending on the circumstances and local laws.

### **Find Dell Latitude Manual :**

[advanced methods for why ai for teachers guide](#)

**what is ai business ideas for beginners**

**advanced methods for why ai image generator guide**

[complete guide to quick ai tools ideas](#)

[quick ai seo tools 2025](#)

**advanced methods for how to ai writing assistant step by step**

[complete guide to easy ai for students for beginners](#)

[complete guide to easy ai chatbot for website tips](#)

[best strategies for how to ai automation](#)

[trending chatgpt prompts tips](#)

[beginner tutorial for quick ai for teachers 2025](#)

**what is agentic ai step by step**

[advanced methods for what is ai for small business step by step](#)

**top ai image generator step by step**

[advanced methods for trending ai seo tools tips](#)

### **Dell Latitude Manual :**

[ponyhof apfelblüte folge 1 3 amazon com tr - Aug 15 2023](#)

web arama yapmak istediğiniz kategoriye seçin

[ponyhof apfelblüte folge 1 3 pqr uiaf gov co - Sep 04 2022](#)

web ponyhof apfelblüte band 9 samson und das große turnier pippa young 2017 03 13 das erste turnier für lena und ihr pony

samson lena trainiert fleißig weil sie so gut

[ponyhof apfelblüte folge 1 3 copy logb fonedog - Mar 30 2022](#)

web ponyhof apfelblute folge 1 3 is approachable in our digital library an online access to it is set as public as a result you can download it instantly our digital library saves in merged

*ponyhof apfelblute folge 1 3 arcade gameplayer club* - Jun 01 2022

web download any of our books in the manner of this one merely said the ponyhof apfelblute folge 1 3 is universally compatible later any devices to read ponyhof apfelblüte band

*ponyhof apfelblüte folge 1 3 young pippa 9783833737411* - May 12 2023

web jan 13 2017 ponyhof apfelblüte folge 1 3 young pippa on amazon com free shipping on qualifying offers ponyhof apfelblüte folge 1 3

**ponyhof apfelblüte folge 1 3 amazon co uk young pippa** - Apr 11 2023

web buy ponyhof apfelblüte folge 1 3 by young pippa leuchtmann christiane isbn 9783833737411 from amazon s book store everyday low prices and free delivery on

**ponyhof apfelblüte folge 1 3 by pippa young christiane** - Sep 23 2021

web jun 4 2023 titel ponyhof apfelblüte folge 1 3 autor en pippa young isbn 3833737417 ean 9783833737411 folge 1 3

lesung ponyhof apfelblüte empfohlen ab 6 jahre laufzeit ca

[ponyhof apfelblute folge 1 3 copy old vulkk](#) - Jan 08 2023

web fairy mom and me 1 ponyhof apfelblüte band 14 paulinas großer traum a unicorn named sparkle soltra the stone charmer has anyone seen jessica jenkins midnight

**ponyhof episodenguide fernsehserien de** - Jan 28 2022

web episodenführer der tv serie staffel 1 staffel 2 staffel 3

*ponyhof apfelblüte loewe verlag* - Mar 10 2023

web ponyhof apfelblüte band 17 hör auf dein herz lotte lottes eltern haben eine Überraschung weil sie allmählich zu groß für ihr pony goldstück wird bekommt sie ein

**ponyhof apfelblute folge 1 3 german amazon sg books** - Oct 05 2022

web hello sign in account lists returns orders cart

*ponyhof apfelblute folge 1 3 pdf monograf* - Aug 03 2022

web getting the books ponyhof apfelblute folge 1 3 now is not type of challenging means you could not abandoned going with ebook addition or library or borrowing from your

*ponyhof apfelblüte folge 1 3 folge 1 3 lesung audio cd* - Jul 14 2023

web ponyhof apfelblüte folge 1 3 folge 1 3 lesung young pippa leuchtmann christiane amazon de books

**ponyhof apfelblüte folge 1 3 by pippa young christiane** - Dec 07 2022

web ponyhof apfelblüte folge 1 3 hörbuch cd pippa young june 3rd 2020 titel ponyhof apfelblüte folge 1 3 autor en pippa young isbn 3833737417 ean 9783833737411 folge 1

**ponyhof apfelblüte folge 1 3 von pippa young 2017 ebay** - Jun 13 2023

web find many great new used options and get the best deals for ponyhof apfelblüte folge 1 3 von pippa young 2017 at the best online prices at ebay free shipping for many

[ponyhof fernsehserien de](#) - Dec 27 2021

web nov 7 2015 22 folgen in 3 staffeln deutsche tv premiere 07 11 2015 tnt glitz alternativtitel ponyhof die show unter dem motto girl bonding mit gaffer tape und

**die buchreihe ponyhof apfelblüte in richtiger reihenfolge** - Nov 25 2021

web die buchreihe wurde von pippa young verfasst und ist für kinder ab 8 jahren geeignet den anfang markierte das buch lena und samson insgesamt umfasst die serie siebzehn

*ponyhof apfelblüte folge 1 3 by pippa young goodreads* - Nov 06 2022

web jan 13 2017 jump to ratings and reviews want to read buy on amazon rate this book ponyhof apfelblüte folge 1 3 pippa young 0 00 0 ratings0 reviews audio cd published

*ponyhof apfelblüte folge 1 3 by young pippa abebooks* - Feb 26 2022

web ponyhof apfelblüte folge 1 3 by young pippa and a great selection of related books art and collectibles available now at abebooks com

*9783833737411 ponyhof apfelblüte folge 1 3 abebooks* - Jul 02 2022

web abebooks com ponyhof apfelblüte folge 1 3 9783833737411 by young pippa and a great selection of similar new used and collectible books available now at great prices

*ponyhof apfelblüte folge 1 3 mira lobe pdf* - Apr 30 2022

web 1 ponyhof apfelblüte folge 1 3 eventually you will totally discover a further experience and achievement by spending more cash nevertheless when attain you recognize that

**ponyhof ponyhof die show news termine streams auf tv** - Oct 25 2021

web 2 02 der knecht vom ponyhof 28 min 2 03 nieder mit der emanzipation 28 min 2 04 zarte klänge der leidenschaft 29 min 2 05 zwischen vernunft und sinnlichkeit 28 min 2 08

**ponyhof apfelblüte folge 1 3 young pippa 9783833737411** - Feb 09 2023

web ponyhof apfelblüte folge 1 3 by young pippa at abebooks co uk isbn 10 3833737417 isbn 13 9783833737411 jumbo neue medien verla 2017

**of mice and men perfection learning** - Oct 15 2023

web a controversial tale of friendship and tragedy during the great depression they are an unlikely pair george is small and quick and dark of face lennie a man of tremendous size has the mind of a young child yet they have formed a family clinging together in the face of loneliness and alienation

**perfection learning corporation of mice and men download only** - Jul 12 2023

web perfection learning corporation of mice and men of mice and men audio cd pack aug 04 2023 of mice and men feb 03 2021 george and lennie are an unlikely pair george is small and quick and lennie is a man of tremendous size and simple mind but together they ve formed a family rallying against seclusion and alienation

*of mice and men section 2 summary analysis sparknotes* - May 10 2023

web book section 2 from lennie and george s arrival at the ranch to an unpleasant encounter with curley summary the next day lennie and george make their way to the ranch bunkhouse where they are greeted by candy an aging swamper or handyman who has lost his right hand

*perfection learning corporation of mice and men john* - Aug 01 2022

web of mice and men to the scoot s father there s just one problem the scoot s father walked out years ago and hasn t been heard from since so guided by steinbeck s life lessons and with only the vaguest of plans nick and jaycee set off to find him characters you ll want to become friends with and a narrative voice that

**perfection learning corporation of mice and men scott adams** - Feb 24 2022

web perfection learning corporation of mice and men getting the books perfection learning corporation of mice and men now is not type of challenging means you could not by yourself going when ebook collection or library or borrowing from your friends to entrance them this is an totally easy means to specifically acquire lead by on line

ebook perfection learning corporation of mice and men - Jan 06 2023

web various mice models of vascular diseases have been reported and these will make a substantial contribution to basic research on cardiovascular and metabolic disorders space mice may 05 2023

perfection learning corporation of mice and men pdf - Jun 30 2022

web oct 21 2023 perfection learning corporation of mice and men 2 downloaded from dev awesomedoodle com on 2019 09 05 by guest book review the fruit hunters by adam leith gollner the new york times theater listings for march 21 27 the new york times 11 best board games of 2023 reviews by wirecutter the new york times

**perfection learning corporation of mice and men copy** - Feb 07 2023

web perfection learning corporation of mice and men of flies mice and men may 01 2021 tells the story of how the marvelous discoveries of molecular and developmental biology are transforming our understanding of who we are and where we came from jacob scrutinizes the place of the scientist in society jacket

**perfection learning** - Jun 11 2023

web we would like to show you a description here but the site won t allow us

[perfection learning corporation of mice and men pdf](#) - May 30 2022

web sep 24 2023 right here we have countless book perfection learning corporation of mice and men and collections to check out we additionally allow variant types and next type of the books to browse the agreeable book fiction history novel scientific research as without difficulty as various other sorts of books are readily manageable here

**perfection learning corporation of mice and men copy** - Mar 08 2023

web of mice and men may 29 2022 of mice and men apr 08 2023 the story two drifters george and his friend lennie with delusions of living off the fat of the land have just arrived at a ranch to work for enough money to buy their own place lennie is a man child a little boy in the body of a dangerousl of mice and men jul 07 2020 study

*about us perfection learning perfection learning* - Nov 04 2022

web print digital and blended solutions for literature language arts and math help students across the country become self directed learners and we continue to listen and learn from our customers leading educators and technology innovators for ideas that will bring easy to use flexible solutions with real results

**of mice and men contemporary classics perfection learning** - Sep 14 2023

web of mice and men contemporary classics reproducible resource packet for teaching 20th century literature

**perfection learning corporation company profile clive ia** - Mar 28 2022

web perfection learning corporation company profile clive ia competitors financials contacts dun bradstreet find company research competitor information contact details financial data for company name of company city state

**k 12 curriculum advanced placement ela perfection learning** - Apr 09 2023

web featured solutions help all your students achieve ap success with our accessible yet rigorous coursebooks help all your students achieve ap success with coursebooks designed by leading experts build critical reading and mathematics foundational skills needed for learning on grade level standards

**perfection learning corporation of mice and men pdf** - Apr 28 2022

web apr 11 2023 perfection learning corporation of mice and men 2 6 downloaded from uniport edu ng on april 11 2023 by guest exam each workbook contains sections to be filled in by the reader of mice and men john steinbeck 1937 tells a story about the strange relationship of two migrant

*perfection learning corporation of mice and men pdf ead3* - Aug 13 2023

web oct 15 2023 perfection learning corporation of mice and men the red pony john steinbeck 1977 07 a young boy dreams great dreams and also learns the harsh realities of life catalog of copyright entries third series library of congress copyright

office 1979 english journal 2000 the acts of king arthur and his noble knights

[perfection learning corporation of mice and men pdf pdf qa](#) - Dec 05 2022

web introduction perfection learning corporation of mice and men pdf pdf teaching tech savvy kids jessica k parker 2010 05 03 written for middle and high school teachers this resource expands educators understanding of the relationship between their students

**management leadership training workshops singapore** - Sep 02 2022

web contact us to schedule a 2 minute call send us a message to find out how we can help your company develop your managers into leaders performance recognition provides manager training and leadership workshops to sharpen individuals managerial leadership skills contact us today to find out more about crestcom s bullet proof manager

*perfection learning corporation of mice and men pdf* - Oct 03 2022

web may 21 2023 perfection learning corporation of mice and men 1 6 downloaded from uniport edu ng on may 21 2023 by guest perfection learning corporation of mice and men this is likewise one of the factors by obtaining the soft documents of this perfection learning corporation of mice and men by online you might not require more grow old to

*integrated marketing* - Sep 05 2022

web kolkata 700 010 phone 033 32449649 mobile 7439040301 dtp by pravin kharche printed at rose fine arts mumbai on behalf of hph

[mba iv integrated mrketing communication 12mbamm417 notes](#) - Feb 10 2023

web integrated marketing communication 12mbamm417 dept of mba sjbit 1 syllabus module 1 role of imc in marketing process imc planning model marketing and promotion process model communication process steps involved in developing imc programme effectiveness of marketing communications advertising purpose role

**integrated marketing communication academia edu** - Jun 14 2023

web this article reviews the literature on imc and then examines its development empirically in turkey in this paper we explore perceptions of imc derived from a sample of advertising agency executives and explore how perceptions of

[mba imc integrated marketing communication](#) - Jul 03 2022

web admissions process 4 after the result is declared candidates will have to fill the programme preferences details online 5 seat allotment candidates will be offered the choice of the programme based on their preference result and availability of seats 1 february 2021 last date to apply 7th february 2021

**rmbmk05 integrated marketing communication theintactone** - Jan 09 2023

web feb 26 2019 unit 1 book link 1 marketing communication objectives of marketing communication view 2 functional areas of marketing communication view 3 integrated marketing communication imc concepts and process view 4 factors

contributing to integrated marketing communication imc view 5 role of integrated marketing  
*integrated marketing communication imc what process mix* - Dec 08 2022

web nov 16 2020 in simple term integrated marketing communication can be defined as the integration of all the forms of communication and messages so that the marketing organization can create an impactful promotional impact on their target and prospective customer groups

**18mbamm402 integrated marketing communication syllabus for mba** - Nov 07 2022

web jan 24 2023 role of imc in marketing process imc planning model marketing and promotion process model communication process steps involved in developing imc programme effectiveness of marketing communications purpose role functions types advertising vs marketing mix advertising appeal in various stages of plc  
*imc notes for mba brandhub futurebrand com* - Feb 27 2022

web module 1 role of imc in marketing process mba marketing notes integrated marketing communications complete notes on imc integrated marketing communication imc mba notes 2018 2019 student forum mini mba integrated marketing communications imc team building and leadership notes for mba comm imc integrated

lecture notes imc unit i pdf marketing communications - Jul 15 2023

web 11 lecture notes imc unit i free download as word doc doc docx pdf file pdf text file txt or read online for free mba imc notes

**imc notes for marketing lecture notes on integrated** - Aug 16 2023

web imc notes for marketing lecture notes on integrated marketing communication ii mba i semester r 16 studocu lecture notes on integrated marketing communication ii mba semester 16 syllabus prepared sunitha assistant professor department of mba master of business skip to document ask ai

*integrated marketing communication imc notes learning* - Mar 11 2023

web sep 1 2022 imc focuses on sales brand image and customer satisfaction dimensions equitably all other functions integrates to maintain all these dimensions integrated approach remarks on a strong favorable positive and unique brand association of products services in the memory of customers

integrated marketing communications imc mba skool - May 13 2023

web integrated marketing communications imc is the process of integrating coordinating and combining the various marketing and promotional elements to deliver the same and consistent marketing message across customers and channels imc makes sure that irrespective of the delivery channel the message and positioning does not change

**marketing notes integrated marketing communications mba** - Apr 12 2023

web about this content basic notes from core mba marketing course focusing on marketing communications subject

marketing table of contents integrated marketing communications the imc planning process the imc planning process  
changing role of advertising seeking benefits in sales promotion

*integrated marketing communication imc mba notes case* - Oct 06 2022

web what is integrated marketing communication imc integrated marketing communication refers to integrating all the  
methods of brand promotion to promote a particular product or service among target customers

*imc notes for mba help environment harvard edu* - May 01 2022

web imc notes for mba if you ally need such a referred imc notes for mba books that will pay for you worth get the utterly  
best seller from us currently from several preferred authors if you desire to droll books lots of novels tale jokes and more  
fictions collections are along with launched from best seller to one of the most current released

*imc notes for mba help discoveram* - Dec 28 2021

web jun 8 2023 we pay for imc notes for mba and abundant books selections from fictions to scientific investigationh in any  
way you might not call for more time frame to invest to go to the ebook launch as proficiently as search for them

**integrated marketing communication mba notesworld** - Aug 04 2022

web feb 9 2009 integrated marketing communication posted by mbanotesworld february 9 2009 imc can be defined as a  
concept of marketing communications planning that recognizes the added value of a comprehensive plan that evaluates the  
strategic roles of a variety of communication disciplines

*imc notes for mba 2023 cyberlab sutd edu sg* - Mar 31 2022

web mba notes jul 14 2023 mba notes is a combination of lecture notes strategic frameworks and useful business and  
management concepts drawn from online sources it is primarily intended for current managers who don t have the time or  
inclination to enroll in an mba program mba alumni that want to refresh the concepts learned during their study

*imc notes for mba uniport edu ng* - Jan 29 2022

web aug 6 2023 mba notes jeff blum 2021 10 03 mba notes is a combination of lecture notes strategic frameworks and  
useful business and management concepts drawn from online sources it is primarily intended for current managers who don t  
have the time or inclination to enroll in an mba program

*pdf notes integrated marketing communication 2023* - Jun 02 2022

web there is a strong need to explore the concept and phenomena of imc directly in the real world of communication  
communication is the basis of all marketing activities the purpose of integrated marketing communications strategy is to  
work toward the common goal of customer focused marketing